



MAX **Series**

As "Max" as Reliable

Diesel/Gasoline Forklift 1.5-10.0t

Contents

MAX-3

CPC/Q(D)20-35T3	01-08
CPCD40T3	09-12

MAX-8

CPC(Q)D15/18/20/25/30/35T8	13-19
CPCD45T8/CPCD50T8-X	20-23
CPCD50-100T8	24-30



高層貨架區
HIGH GOODS-SHELF SECTION

二三四五區

一層·四區

MAX-3



MAX-3

Innovation to Create New Market

CPC/Q(D)20-35T3

Diesel/Gasoline Forklift 2.0/2.5/3.0/3.5t

EP EQUIPMENT CO.,LTD
www.ep-ep.com



CPC/Q(D)20T3

T3 series 2.0 forklift specification:

General		EP		EP		EP		EP		EP		EP		EP	
Model	Power type	Rated capacity	Load center	Lift height	Free lift height	Fork size	Mast lift range	Fork overhang(wheel center to fork face)	Rear overhang	Length to face of fork	Overall width	Overall dimensions	Mast extended height	Mast extended height	Overhead guard height
1 Manufacture															
2 Model															
3 Power type															
4 Rated capacity															
5 Load center															
6 Lift height															
7 Free lift height															
8 Fork size															
9 Mast lift range															
10 Fork overhang(wheel center to fork face)															
11 Rear overhang															
12 Length to face of fork															
13 Overall width															
14 Overall dimensions															
15 Mast extended height															
16 Mast extended height															
17 Overhead guard height															
18 Turning radius(outside)															
19 Travel (No load)															
20 Lifting (Full load)															
21 Lowering (Full load)															
22 Max. Drawbar Pull (Full load)															
23 Max. Gradeability (Full load)															
24 Tyres															
25 Front															
26 Rear															
27 Tread															
28 Wheelbase															
29 Ground clearance															
30 Wheelbase center															
31 Self weight															
32 Front															
33 Rear															
34 Weight Distribution															
35 No load															
36 Voltage/Capacity(20HR)															
37 Modal															
38 Manufacture															
39 Rated output/r.p.m															
40 Rated torque/r.p.m															
41 No. of cylinder															
42 Bore*Stroke															
43 Displacement															
44 Emission standard															
45 Fuel tank capacity															
46 Manufacture															
47 Type															
48 Stage															
49 Operating pressure															

1. Special lifting height available (2-stage mast : 2.5m, 2.7m, 3.0m,3.3m, 3.5m,3.6m, 3.7m,4m,4.3m, 4.5m,5m. Full Free Duplex Mast 3.0m,3.3m,3.5m,3.6m,4.0m. 3-stage mast : 4.3m, 4.5m, 4.8m,5m, 5.5m, 6m,6.5m,7.0m)
 2. Attachment available. 3. The specification in the table are for standard models only . For further information please contact us. 4. Specification are subject to change without notice.

CPC/Q(D)25T3

T3 series 2.5 forklift specification:

General		EP		EP		EP		EP		EP	
1	Manufacturer	CPC25T3	CPCD25T3	CPCD25T3	CPCD25T3	CPCD25T3	CPCD25T3	CPCD25T3	CPCD25T3	CPCD25T3	CPQD25T3
2	Model	Diesel	Diesel	Diesel	Diesel	Diesel	Diesel	Diesel	Diesel	Diesel	Gasoline
3	Power type										
4	Rated capacity	Kg	2500	2500	2500	2500	2500	2500	2500	2500	2500
5	Load center	mm	500	500	500	500	500	500	500	500	500
6	Lift height	mm	3000	3000	3000	3000	3000	3000	3000	3000	3000
7	Free lift height	mm	120	120	120	120	120	120	120	120	120
8	Fork size	LxWxT	1070x120x40	1070x120x40	1070x120x40	1070x120x40	1070x120x40	1070x120x40	1070x120x40	1070x120x40	1070x120x40
9	Mast tilt range	F/R	6/10	6/10	6/10	6/10	6/10	6/10	6/10	6/10	6/10
10	Fork overhang(wheel center to fork face)	K	481	481	481	481	481	481	481	481	481
11	Rear overhang	M	500	500	500	500	500	500	500	500	500
12	Length to face of fork	Y	2580	2580	2580	2580	2580	2580	2580	2580	2580
13	Overall width	Q	1150	1150	1150	1150	1150	1150	1150	1150	1150
14	Mast lowered height	C	2050	2050	2050	2050	2050	2050	2050	2050	2050
15	Mast extended height	A	4200	4200	4200	4200	4200	4200	4200	4200	4200
16	Overhead guard height	P	2160	2160	2160	2160	2160	2160	2160	2160	2160
17	Turning radius(outside)	R	2240	2240	2240	2240	2240	2240	2240	2240	2240
18	Travel (No load)	Km/h	8/20	20	20	20	20	20	20	20	20
19	Lifting (Full load)	mm/sec	360	360	360	360	360	360	360	360	360
20	Lowering (Full load)	mm/sec	400	400	400	400	400	400	400	400	400
21	Max.Drawbar Pull (Full load)	N	14500	14500	14500	14500	14500	14500	14500	14500	14500
22	Max.Gradeability (Full load)	%	20	20	20	20	20	20	20	20	20
23	Tyres	Front	700-12-12PR	700-12-12PR	700-12-12PR	700-12-12PR	700-12-12PR	700-12-12PR	700-12-12PR	700-12-12PR	700-12-12PR
24		Rear	600-9-10PR	600-9-10PR	600-9-10PR	600-9-10PR	600-9-10PR	600-9-10PR	600-9-10PR	600-9-10PR	600-9-10PR
25	Tread	Front	970	970	970	970	970	970	970	970	970
26		Rear	970	970	970	970	970	970	970	970	970
27	Wheelbase	L	1600	1600	1600	1600	1600	1600	1600	1600	1600
28	Ground clearance	Lowest	135/120	135/120	135/120	135/120	135/120	135/120	135/120	135/120	135/120
29	Wheelbase center	mm	160/145	160/145	160/145	160/145	160/145	160/145	160/145	160/145	160/145
30	Self weight	Kg	3770	3770	3770	3770	3770	3770	3770	3770	3770
31	Weight	Front	5480	5480	5480	5480	5480	5480	5480	5480	5480
32		Rear	790	790	790	790	790	790	790	790	790
33	Distribution	No load	1410	1410	1410	1410	1410	1410	1410	1410	1410
34	Battery	Voltage/Capacity(20HR)	2360	2360	2360	2360	2360	2360	2360	2360	2360
35		Modal	C490BPG-25	C490BPG-25	C490BPG-25	C490BPG-25	C490BPG-25	C490BPG-25	C490BPG-25	C490BPG-25	GK25
36	Manufacture	CHINA	CHINA	CHINA	CHINA	CHINA	CHINA	CHINA	CHINA	CHINA	GCT
37	Rated output/r.p.m	kw	36.8/2650	36.8/2650	36.8/2650	36.8/2650	36.8/2650	36.8/2650	36.8/2650	36.8/2650	37.4/2300
38	Rated torque/r.p.m	N.m	156/1700-1900	156/1700-1900	156/1700-1900	156/1700-1900	156/1700-1900	156/1700-1900	156/1700-1900	156/1700-1900	176.5/1600
39	No.of cylinder	4	4	4	4	4	4	4	4	4	4
40	Borex-stroke	mm	90x105	90x105	90x105	90x105	90x105	90x105	90x105	90x105	89x100
41	Displacement	cc	2670	2670	2670	2670	2670	2670	2670	2670	2488
42	Emission standard		EURIII	EURIII	EURIII	EURIII	EURIII	EURIII	EURIII	EURIII	/
43	Fuel tank capacity	L	60	60	60	60	60	60	60	60	/
44	Manufacture	CHINA	CHINA	CHINA	CHINA	CHINA	CHINA	CHINA	CHINA	CHINA	CHINA
45	Transmissions Type	Mechanical	Powershift	Powershift	Powershift	Powershift	Powershift	Powershift	Powershift	Powershift	Powershift
46	Stage		2/2	2/2	2/2	2/2	2/2	2/2	2/2	2/2	1/1
47	Operating pressure	Mpa	17.5	17.5	17.5	17.5	17.5	17.5	17.5	17.5	17.5

1. Special lifting height available (2-stage mast : 2.5m, 2.7m, 3.0m,3.3m, 3.5m,3.6m, 3.7m,4m,4.3m, 4.5m,5m, Full Free Duplex Mast 3.0m,3.3m,3.5m,3.6m,4.0m, 3-stage mast : 4.3m, 4.5m, 4.8m,5m, 5.5m, 6m,6.5m, 7.0m)
 2. Attachment available. 3. The specification in the table are for standard models only . For further information please contact us. 4. Specification are subject to change without notice.

CPC/Q(D)30T3

T3 series 3.0 forklift specification:

General		EP		EP		EP		EP		EP		EP	
1	2	3	4	5	6	7	8	9	10	11	12	13	14
1	Manufacture												
2	Model												
3	Power type												
4	Rated capacity												
5	Load center												
6	Lift height												
7	Free lift height												
8	Fork size												
9	Mast tilt range												
10	Fork overhang(wheel center to fork face)												
11	Rear overhang												
12	Length to face of fork												
13	Overall width												
14	Overall height												
15	Dimensions												
16	Overall height												
17	Turning radius(outside)												
18	Travel (No load)												
19	Speed												
20	Lowering (Full load)												
21	Max.Drawbar Pull (Full load)												
22	Max.Gradeability (Full load)												
23	Tyres												
24	Front												
25	Rear												
26	Tread												
27	Wheelbase												
28	Ground clearance												
29	Wheelbase center												
30	Self weight												
31	Full load												
32	Rear												
33	Front												
34	Rear												
35	Battery												
36	Voltage/Capacity(20HR)												
37	Model												
38	Manufacture												
39	Rated output/r.p.m												
40	Engine												
41	Bore×Stroke												
42	Displacement												
43	Emission standard												
44	Fuel tank capacity												
45	Manufacture												
46	Type												
47	Stage												
48	Operating pressure												

1. Special lifting height available (2-stage mast : 2.5m, 2.7m, 3.0m,3.3m, 3.5m,3.6m, 3.7m,4m,4.3m, 4.5m,5m. Full Free Duplex Mast 3.0m,3.3m,3.5m,3.6m,4.0m. 3-stage mast : 4.3m, 4.5m, 4.8m,5m, 5.5m, 6m,6.5m,7.0m)
 2. Attachment available. 3. The specification in the table are for standard models only . For further information please contact us. 4. Specification are subject to change without notice.

Mast Option

2.0-2.5t T3 series mast: (pneumatic)

Type	Model	Max.fork height	Overall height			Free lift		Front Overhang		Tilt range		Capacity			
			Lowered	Extended		Without backrest	With backrest			FWD	BWD	Load capacity at 500 mm			
				Without backrest	With backrest							Single tire		Double tire	
			mm	mm	mm	mm	mm	mm	mm	Deg	Deg	2.0t	2.5t	2.0t	2.5t
Wide view mast	2W200	2000	1555	2740	3420	120	120	476	476	6	10	2000	2500	2000	2500
	2W250	2500	1805	3040	3720	120	120	476	476	6	10	2000	2500	2000	2500
	2W270	2700	1905	3240	3920	120	120	476	476	6	10	2000	2500	2000	2500
	2W300	3000	2055	3540	4220	120	120	476	476	6	10	2000	2500	2000	2500
	2W330	3300	2205	3690	4370	120	120	476	476	6	10	2000	2500	2000	2500
	2W350	3500	2305	3890	4570	120	120	476	476	6	10	2000	2500	2000	2500
	2W360	3600	2355	3990	4670	120	120	476	476	6	10	2000	2500	2000	2500
	2W400	4000	2605	4040	4720	120	120	476	476	6	10	1900	2300	2000	2500
	2W430	4300	2755	4340	5020	120	120	476	476	6	6	1800	2100	1950	2450
2W450	4500	2855	4290	4970	120	120	476	476	6	6	1700	2000	1900	2400	
Wide view full 2-stage mast	2F250	2500	1785	2090	2770	1210	560	476	476	6	10	2000	2500	2000	2500
	2F270	2700	1885	2290	2970	1310	660	476	476	6	10	2000	2500	2000	2500
	2F300	3000	2035	2590	3270	1460	810	476	476	6	10	2000	2500	2000	2500
	2F330	3300	2185	3840	4520	1610	960	476	476	6	10	2000	2500	2000	2500
	2F360	3600	2335	4140	4820	1760	1110	476	476	6	10	2000	2500	2000	2500
	2F400	4000	2585	4540	5220	2060	1410	476	476	6	10	1900	2300	2000	2500
Wide view full 3-stage mast	3F430	4300	2035	4880	5560	1360	730	490	490	6	6	1700	2000	1900	2400
	3F450	4500	2115	5040	5720	1460	810	490	490	6	6	1600	1900	1800	2300
	3F480	4800	2220	5345	6020	1565	915	490	490	6	6	1500	1700	1700	2100
	3F500	5000	2305	5540	6220	1610	960	490	490	6	6	1400	1600	1600	2000
	3F550	5500	2555	6120	6800	1770	1120	490	490	3	6	1050	1200	1500	1800
	3F600	6000	2805	6540	7220	2020	1370	490	490	3	6	700	800	1400	1600

Note:1、With sideshifter minus 150Kg, with integral sideshifter minus 100Kg.

3.0-3.5t T3 series mast: (pneumatic)

Type	Model	Max.fork height	Overall height			Free lift		Front Overhang		Tilt range		Capacity			
			Lowered	Extended		Without backrest	With backrest			FWD	BWD	Load capacity at 500 mm			
				Without backrest	With backrest							Single tire		Double tire	
			mm	mm	mm	mm	mm	mm	mm	mm	Deg	Deg	3.0t	3.0t	3.5t
Wide view mast	2W200	2000	1570	2570	3250	120	120	481	486	6	10	3000	3000	3500	3500
	2W250	2500	1820	3070	3750	120	120	481	486	6	10	3000	3000	3500	3500
	2W270	2700	1920	3270	3950	120	120	481	486	6	10	3000	3000	3500	3500
	2W300	3000	2070	3570	4250	120	120	481	486	6	10	3000	3000	3500	3500
	2W330	3300	2220	3690	4370	120	120	481	486	6	10	3000	3000	3500	3500
	2W350	3500	2320	3890	4570	120	120	481	486	6	10	3000	3000	3500	3500
	2W360	3600	2370	3990	4670	120	120	481	486	6	10	3000	3000	3500	3500
	2W400	4000	2620	4040	4720	120	120	481	486	6	10	2850	3000	3250	3500
	2W430	4300	2770	4340	5020	120	120	481	486	6	6	2700	2900	3000	3400
2W450	4500	2870	4290	4970	120	120	481	486	6	6	2550	2850	2850	3350	
wide view full 2-stage mast	2F250	2500	1805	2220	2900	1210	560	481	486	6	10	3000	3000	3500	3500
	2F270	2700	1905	2320	3000	1310	660	481	486	6	10	3000	3000	3500	3500
	2F300	3000	2055	2620	3300	1460	810	481	486	6	10	3000	3000	3500	3500
	2F330	3300	2205	3870	4550	1610	960	481	486	6	10	3000	3000	3500	3500
	2F360	3600	2355	4020	4700	1760	1110	481	486	6	10	3000	3000	3500	3500
	2F400	4000	2605	4420	5100	2060	1410	481	486	6	10	2850	3000	3250	3500
wide view full 3-stage mast	3F430	4300	2055	4910	5570	1360	730	495	500	6	6	2550	2850	2850	3350
	3F450	4500	2135	5070	5750	1460	810	495	500	6	6	2400	2700	2700	3200
	3F480	4800	2240	5375	6050	1565	915	495	500	6	6	2250	2550	2450	2950
	3F500	5000	2325	5570	6250	1610	960	495	500	6	6	1650	2250	2300	2800
	3F550	5500	2575	6150	6830	1770	1120	495	500	3	6	1800	2250	1800	2550
	3F600	6000	2825	6570	7250	2020	1370	495	500	3	6	1200	2100	1300	2300

Note:1、With sideshifter minus 200Kg, with integral sideshifter minus 150Kg.

RATED CAPACITIES AND LOAD CENTERS GRAPH

CPC/Q(D)20T3

SUBTRACT 150kg WITH SIDESHIFTER

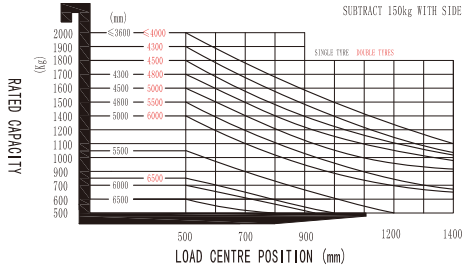

RATED CAPACITIES AND LOAD CENTERS GRAPH

CPC/Q(D)30T3

SUBTRACT 200kg WITH SIDESHIFTER

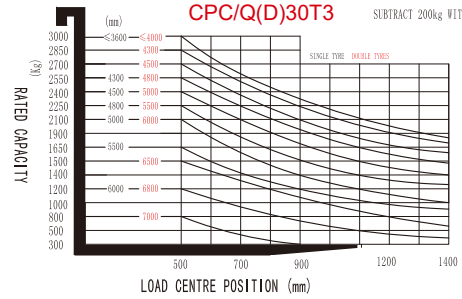

RATED CAPACITIES AND LOAD CENTERS GRAPH

CPC/Q(D)25T3

SUBTRACT 150kg WITH SIDESHIFTER

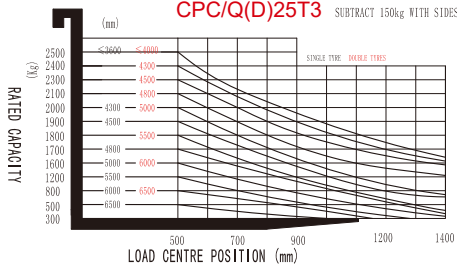

RATED CAPACITIES AND LOAD CENTERS GRAPH

CPC/Q(D)35T3

SUBTRACT 200kg WITH SIDESHIFTER

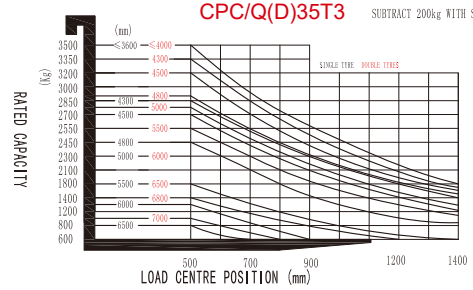

Option

Options	20T3	25T3	30T3	35T3
1 Fork length	○	○	○	○
2 Fork extension	○	○	○	○
3 Folded fork	○	○	○	○
4 Imported diesel engine	○	○	○	○
5 Import Gasoline Engine	○	○	○	○
8 LPG system	○	○	○	○
9 High exhaust	○	○	○	○
10 Double air filtration	○	○	○	○
11 Solid rubber tire	○	○	○	○
12 No marking solid tire	○	○	○	○
14 Overhead guard	○	○	○	○
15 Mast options	○	○	○	○
16 Attachments	○	○	○	○
17 Integrated side shift	○	○	○	○
19 Cockpit	●	●	●	●
20 Heater	○	○	○	○
21 Front windshield with wiper	○	○	○	○
22 Rear windshield with wiper	○	○	○	○
23 Simple cabin room	○	○	○	○
24 LED lights	○	○	○	○
25 Fire extinguisher	○	○	○	○
26 Suspension seat	○	○	○	○
27 Seat switch	○	○	○	○
28 Warning light	○	○	○	○
29 Insulation mat	○	○	○	○
30 Double front tyre	○	○	○	○
31 Front work light	●	●	●	●
32 Rear working LED light	○	○	○	○
33 OPS system	○	○	○	○
34 fan	○	○	○	○

Note: ● standard ○ option — NA

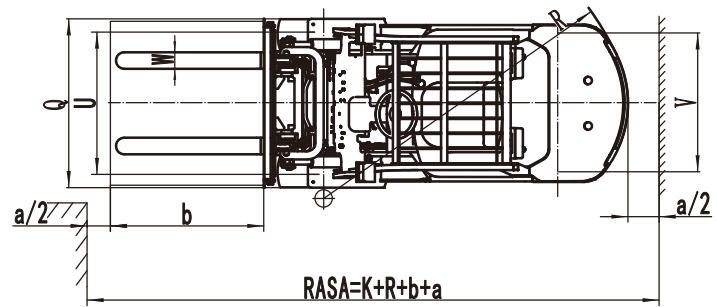
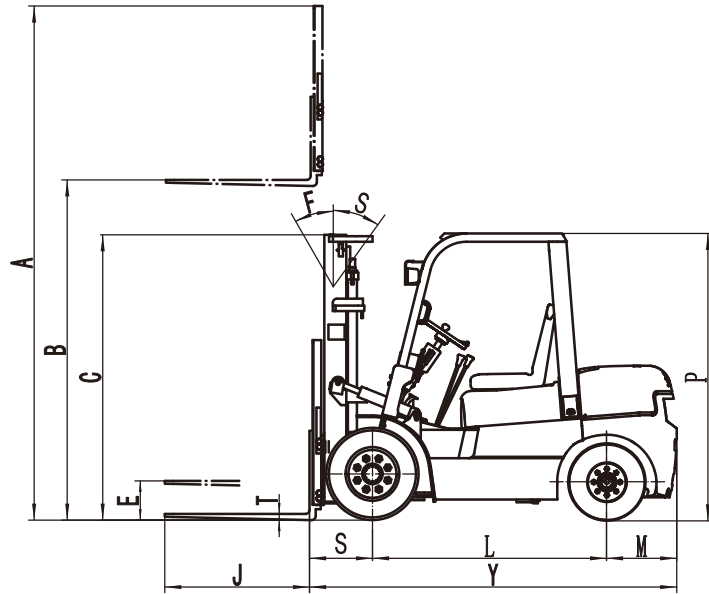

MAX-3



MAX-3

Excellent Performances & Reliability

CPCD40T3

T3 Diesel Forklift 4.0t

EP EQUIPMENT CO.,LTD
www.ep-ep.com

CPCD40T3

T3 Diesel Forklift 4.0t

General		CPD40T3	EP	CPD40T3
1	Manufacture			CPD40T3
2	Model		Diesel	Diesel
3	Power type		4000	4000
4	Rated capacity	kg	500	500
5	Load center	mm	3000	3000
6	Lift height	mm	110	110
7	Free lift height	mm	1070*140*50	1070*140*50
8	Fork size	LxUxN	6/10	6/10
9	Mast tilt angle	K/T	510	510
10	Front overhang	mm	565	565
11	Rear overhang	mm	2900	2900
12	Length to face of fork	mm	1410	1410
13	Overall width	mm	2235	2235
14	Mast lowered height	mm	4110	4110
15	Mast extended height	mm	2190	2190
16	Overhead guard height	mm	2700	2700
17	Turning radius	mm	9/19	18/16
18	Travel speed	II/ I	470/380	470/380
19	no load/full load	mm/sec	400	400
20	Lift speed	mm/sec	15	15
21	Lowering (Full load)	%	250-15-16PR	250-15-16PR
22	Max. gradeability		7.00-12-12PR	7.00-12-12PR
23	Tires	Front	1160	1160
24	Rear	Q (Front)	1100	1100
25	Tread	S (Rear)	1860	1860
26	Wheelbase		150/120	150/120
27	Ground clearance	mast frame	178/175	178/175
28	no load/full load		5200	5200
30	Self weight		1850	1850
31	Full load	Front	3250	3250
32	Rear	Rear	8100	8100
33	Weight Distribution	No load	1100	1100
34	Displacement		12V80Ah	12V80Ah
35	Battery	Model	NE98	4D32G31
36	Manufacture		YANMAR	YANMAR
37	Rated output	kw/rpm	42.1/2300	36.8/2500
38	Rated torque	N.m/rpm	186/1700	186/1700
39	Engine	No.of cylinder	4	4
40	Bore*stroke	mm	98x110	98x110
41	Displacement	cc	3319	3166
42	Type		Mechanical	Mechanical / Powershift
43	Shift		II	II
44	Transmissions			

1.The parameters in the table are of the standard model. For more information, please contact us.
 2.The parameters are subject to change without notice.

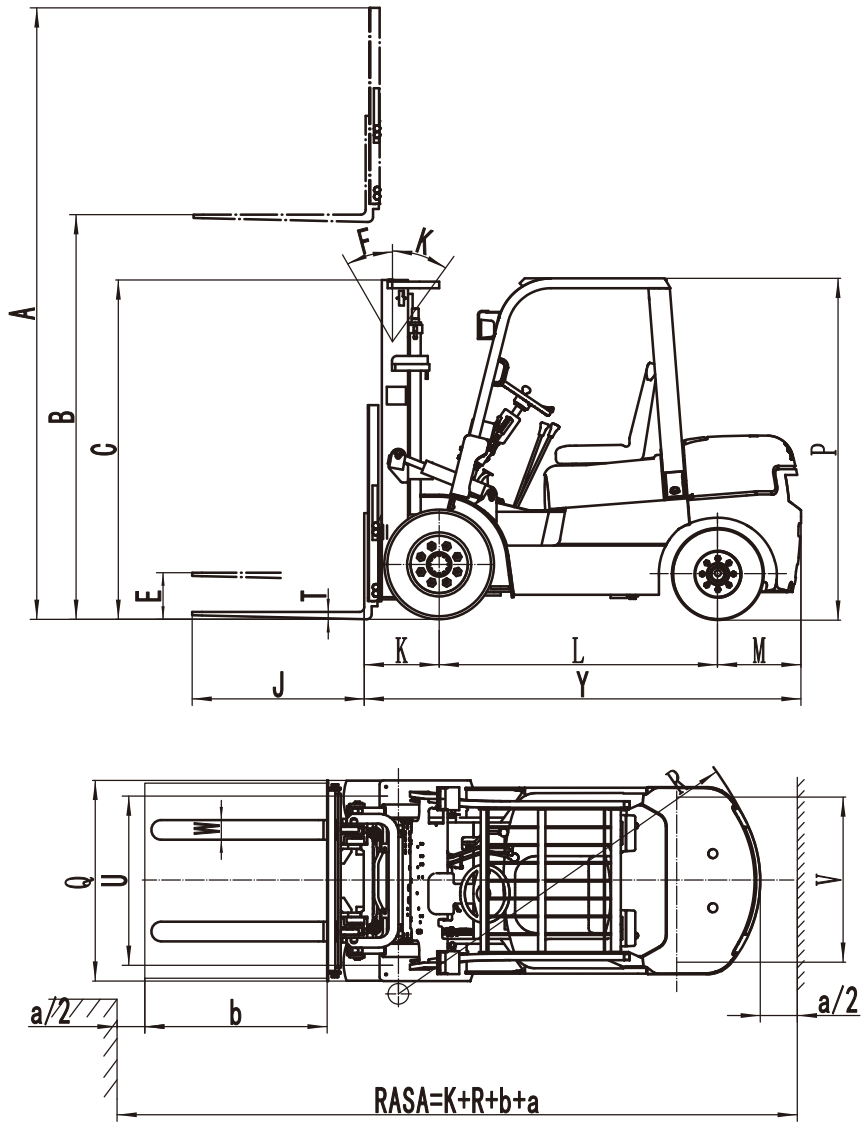

Mast Option

Type	Model	Max. fork height	Overall height		Free lift		Front Overhang	Tilt range		Capacity	
			Lowered	Extended		Without backrest		With backrest	FWD	BWD	Load capacity at 500 mm
				Without backrest	With backrest						Single tire
		mm	mm	mm	mm	mm	mm	Deg	Deg	kg	
Wide view mast	2W300	3000	2256	2966	3356	130	130	497	6	10	4000
	2W330	3300	2406	3116	3506	130	130	497	6	10	4000
	2W350	3500	2506	3216	3606	130	130	497	6	10	3850
	2W360	3600	2556	3266	3656	130	130	497	6	10	3800
	2W370	3700	2606	3316	3706	130	130	497	6	10	3700
	2W400	4000	2806	3516	3906	130	130	497	6	10	3600

CAPACITY CHART

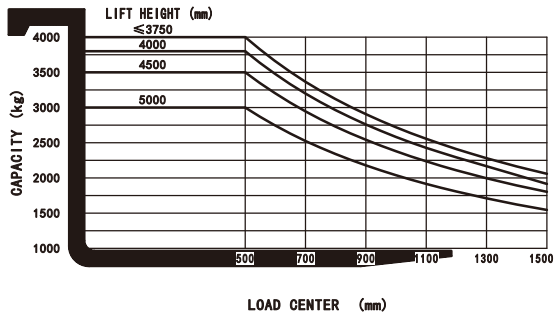

Option

Options		CPC(D)40T3
1	Fork length	○
2	Fork extension	○
3	Folded fork	○
4	Imported diesel engine	○
5	High exhaust	○
6	Dual air cleaners or special air cleaner	○
7	Solid rubber tire	○
8	No marking solid tire	○
9	Overhead guard	○
10	Mast options	○
11	Attachments	○
12	Integrated side shift	○
13	Heater	○
14	Front windshield with wiper	○
15	Rear windshield with wiper	○
16	Fan	○
17	Simple cabin room	○
18	LED front light	○
19	LED Back light	○
20	Fire extinguisher	○
21	Suspension seat	○
22	Seat switch	○
23	Warning light	○
24	Insulation mat	○
25	Double front tyre	○
26	OPS system	○

Note: ● standard ○ option — NA

MAX-8



MAX-8

Excellent Performances & Reliability

CPC(Q)D15/18/
20/25/30/35T8

T8 series 1.5–3.5t forklift

EP EQUIPMENT CO.,LTD
www.ep-ep.com



CPC(Q)D15/18T8

T8 series 1.5-1.8t forklift specification

		EP					
		CPQD15T8-S4Q 2	CPQD15T8-NB485BPG	CPQD15T8-GK21	CPQD18T8-S4Q2	CPQD18T8-NB485BPG	CPQD18T8-GK21
1	Manufacture						
2	Model						
3	Power type		Diesel	Gasoline	Diesel	Diesel	Gasoline
4	Rated capacity		1500	1500	1800	1800	1800
5	Load center		500	500	500	500	500
6	Lift height		3000	3000	3000	3000	3000
7	Free lift height		120	120	120	120	120
8	Fork size	L×W×T	920×100×35	920×100×35	920×100×35	920×100×35	920×100×35
9	Mast lift range	F/R	612	612	612	612	612
10	Fork overhang(wheel center to fork face)		420	420	420	420	420
11	Rear overhang		420	420	420	420	420
12	Length to face of fork		2230	2230	2230	2230	2230
13	Overall width		1080	1080	1080	1080	1080
14	Mast lowered height		1985	1985	1985	1985	1985
15	Mast extended height		3960	3960	3960	3960	3960
16	Overhead guard height		2070	2070	2070	2070	2070
17	Turning radius(outside)		1995	1995	2035	2035	2035
18	Min.right angle stacking aisle width (Add load length and clearance)		2400	2400	2440	2440	2440
19	Travel (No load)		14	14	14	14	14
20	Speed		460	460	460	460	460
21	Lifting (Full load)		450	450	450	450	450
22	Lowering (Full load)		450	450	450	450	450
23	Max.Drawbar Pull (Full load)		20500(17500)	20500(17500)	20500(17500)	20500(17500)	20500(17500)
24	Max.Gradeability (Full load)		20	20	20	20	20
25	Tyres	Front	6.50-10-10PR	6.50-10-10PR	6.50-10-10PR	6.50-10-10PR	6.50-10-10PR
26	Tread	Rear	5.00-8-10PR	5.00-8-10PR	5.00-8-10PR	5.00-8-10PR	5.00-8-10PR
27	Wheelbase		920	920	920	920	920
28	Ground clearance		1430	1430	1430	1430	1430
29	Wheelbase center		110	110	110	110	110
30	Self weight		145	145	145	145	145
31	Weight	Full load	2700	2700	2700	2900	2900
32	Weight	Rear	3570	3570	3570	3985	3985
33	Weight	Front	630	630	705	705	705
34	Distribution	Front	1215	1215	1215	1305	1305
35	Battery	Rear	1485	1485	1485	1585	1585
36	Voltage/Capacity(20HR)		12/60	12/60	12/60	12/60	12/60
37	Modal		S4Q2	NB485BPG	S4Q2	NB485BPG	GK21
38	Manufacture		Mitsubishi	CHINA	Mitsubishi	CHINA	GCT
39	Rated output/p.m		32.9/2500	30/2600	31.2/2250	30/2600	31.2/2250
40	Rated torque/p.m		135/2000	131/1800	143.7/1600	131/1800	143.7/1600
41	No.of cylinder		4	4	4	4	4
42	Bore×Stroke		88×103	85X100	88×103	85X100	89×83
43	Displacement		2505	2270	2505	2270	2065
44	Fuel tank capacity		50	50	50	50	50
45	Manufacture		CHINA	CHINA	CHINA	CHINA	CHINA
46	Transmissions Type		Powershift	Powershift	Powershift	Powershift	Powershift
47	Stage		1/1	1/1	1/1	1/1	1/1
48	Operating pressure	For attachments	17.5	17.5	17.5	17.5	17.5

1. Special lifting height available (2-stage mast : 2.5m, 2.7m, 3.0m,3.3m, 3.5m,3.6m, 3.7m,4m,4.3m, 4.5m,5m, Full Free Duplex Mast 3.0m,3.3m,3.5m,3.6m, 3-stage mast : 4.3m, 4.5m, 4.8m, 5m, 5.5m, 6m)

3. The parameters in the table are of the standard model. For more information, please contact us. 4. Specification are subject to change without notice.

2. Attachment available.

CPC(Q)D20/25T8

T8 series 2.0-2.5t forklift specification

		EP											
General		CPCD30TB-S4S	CPCD30TB-C490	CPCD30TB-A498	CPCD30TB-C240	CPCD30TB-TD27	CPCD30TB-GK25	CPCD30TB-S4S	CPCD30TB-A498	CPCD30TB-TD27	CPCD30TB-GK25	Diesel	Gasoline
1	Manufacture												
2	Model												
3	Power type	Diesel	Diesel	Diesel	Diesel	Diesel	Diesel	Diesel	Diesel	Diesel	Diesel	Diesel	Gasoline
4	Rated capacity	3000	3000	3000	3000	3000	3000	3000	3000	3000	3000	3000	3500
5	Load center	500	500	500	500	500	500	500	500	500	500	500	500
6	Lift height	3000	3000	3000	3000	3000	3000	3000	3000	3000	3000	3000	3000
7	Free lift height	120	120	120	120	120	120	120	120	120	120	120	120
8	Fork size	1070×125×45	1070×125×45	1070×125×45	1070×125×45	1070×125×45	1070×125×45	1070×125×45	1070×125×45	1070×125×45	1070×125×45	1070×125×45	1070×125×50
9	Mast lift range	F/R	F/R	F/R	F/R	F/R	F/R	F/R	F/R	F/R	F/R	F/R	F/R
10	Fork orienting(wheel center to fork face)	mm	481	481	481	481	481	481	481	481	481	481	486
11	Rear overhang	mm	590	590	590	590	590	590	590	590	590	590	590
12	Length to face of fork	mm	2762	2762	2762	2762	2762	2762	2762	2762	2762	2762	2822
13	Overall width	mm	1200	1200	1200	1200	1200	1200	1200	1200	1200	1200	1200
14	Overall dimensions	mm	2070	2070	2070	2070	2070	2070	2070	2070	2070	2070	2070
15	Mast lowered height	mm	4210	4210	4210	4210	4210	4210	4210	4210	4210	4210	4210
16	Mast extended height	mm	2180	2180	2180	2180	2180	2180	2180	2180	2180	2180	2180
17	Overhead guard height	mm	2450	2450	2450	2450	2450	2450	2450	2450	2450	2450	2510
18	Turning radius(outside)	mm	2950	2950	2950	2950	2950	2950	2950	2950	2950	2950	3010
19	Min.right angle stacking aisle width (Add load length and clearance)	mm	20	20	20	20	20	20	20	20	20	20	20
20	Travel (No load)	Km/h	20	20	20	20	20	20	20	20	20	20	20
21	Speed	mm/sec	400	400	400	400	400	400	400	400	400	400	400
22	Lifting (Full load)	mm/sec	400	400	400	400	400	400	400	400	400	400	400
23	Lowering (Full load)	mm/sec	400	400	400	400	400	400	400	400	400	400	400
24	Max.Drawbar Pull (Full load)	N	21000	21000	21000	21000	21000	21000	21000	21000	21000	21000	21500
25	Max.Gradeability (Full load)	%	20	20	20	20	20	20	20	20	20	20	20
26	Types	mm	28×9-15-12PR	28×9-15-12PR	28×9-15-12PR	28×9-15-12PR	28×9-15-12PR	28×9-15-12PR	28×9-15-12PR	28×9-15-12PR	28×9-15-12PR	28×9-15-12PR	28×9-15-12PR
27	Tread	mm	6.50-10-10PR	6.50-10-10PR	6.50-10-10PR	6.50-10-10PR	6.50-10-10PR	6.50-10-10PR	6.50-10-10PR	6.50-10-10PR	6.50-10-10PR	6.50-10-10PR	6.50-10-10PR
28	Wheelbase	mm	1010	1010	1010	1010	1010	1010	1010	1010	1010	1010	1010
29	Ground clearance	mm	980	980	980	980	980	980	980	980	980	980	980
30	Wheelbase center	mm	1700	1700	1700	1700	1700	1700	1700	1700	1700	1700	1700
31	Self weight	Kg	140	140	140	140	140	140	140	140	140	140	140
32	Weight	mm	175	175	175	175	175	175	175	175	175	175	175
33	Distribution	mm	4450	4450	4450	4450	4450	4450	4450	4450	4450	4450	4450
34	Full load	mm	6488	6488	6488	6488	6488	6488	6488	6488	6488	6488	6488
35	No load	mm	962	962	962	962	962	962	962	962	962	962	962
36	Battery	V/AH	1810	1810	1810	1810	1810	1810	1810	1810	1810	1810	1810
37	Voltage/Capacity(20HR)	mm	2640	2640	2640	2640	2640	2640	2640	2640	2640	2640	2640
38	Manufacture	mm	12/60	12/60	12/60	12/60	12/60	12/60	12/60	12/60	12/60	12/60	12/60
39	Related output/r.p.m	mm	S4S-DPEU2	C490BFG-25	A498BT1-39	C240	TD27	GK25	A498BT1-39	TD27	GK25	GCT	GCT
40	Related torque/r.p.m	mm	ISUZU	CHINA	CHINA	ISUZU	GCT	Mitsubishi	CHINA	CHINA	GCT	GCT	GCT
41	No. of cylinder	mm	35.3/2250	36.8/2400	36.8/2400	34.5/2500	38.5/2300	38.5/2300	35.3/2250	38.5/2300	36.8/2400	38.5/2300	37.4/2300
42	Bore×Stroke	mm	156/1700-1900	186/1600-1800	186/1600-1800	139/1800	160/2300	176.5/1600	177/1700	186/1600-1800	160/2300	176.5/1600	176.5/1600
43	Displacement	cc	4	4	4	4	4	4	4	4	4	4	4
44	Fuel tank capacity	mm	94×120	96×105	88×102	2860	2369	2663	2488	89×100	95×105	96/92	89×100
45	Manufacture	L	3331	2670	2680	70	70	60	3331	2980	2663	2663	2488
46	Type	mm	CHINA	CHINA	CHINA	CHINA	CHINA	CHINA	CHINA	CHINA	CHINA	CHINA	CHINA
47	Stage	Mpa	1/1	2/2	2/2	1/1	1/1	1/1	1/1	1/1	2/2	1/1	1/1
48	Operating pressure		17.5	17.5	17.5	17.5	17.5	17.5	17.5	17.5	17.5	17.5	17.5

1. Special lifting height available (2-stage mast : 2.5m, 2.7m, 3.0m,3.3m, 3.5m,3.6m, 3.7m,4m,4.3m, 4.5m,5m, Full Free Duplex Mast 3.0m,3.3m,3.5m,3.6m, 3-stage mast : 4.3m, 4.5m, 4.8m, 5m, 5.5m, 6m)
 3. The parameters in the table are of the standard model. For more information, please contact us. 4. Specification are subject to change without notice.

2. Attachment available.

CPC(Q)D30/35T8

T8 series 3.0-3.5t forklift specification

		EP													
1	Manufacture	CPCD20T8-S4S	CP-C240	CPD20T8-C240	CPD20T8-GK25	CPD20T8-TD27	CPD20T8-S4S	CPD20T8-C240	CPD20T8-GK25	CPD20T8-TD27	CPD20T8-S4S	CPD20T8-C240	CPD20T8-GK25	CPD20T8-TD27	CPD20T8-GK25
2	Model	Diesel	Diesel	Diesel	Gasoline	Diesel	Diesel	Diesel	Gasoline	Diesel	Diesel	Diesel	Gasoline	Diesel	Gasoline
3	Power type	2000	2000	2000	2000	2000	2000	2000	2000	2000	2000	2000	2000	2000	2500
4	Rated capacity	500	500	500	500	500	500	500	500	500	500	500	500	500	500
5	Load center	mm	mm	mm	mm	mm	mm	mm	mm	mm	mm	mm	mm	mm	mm
6	Lift height	mm	mm	mm	mm	mm	mm	mm	mm	mm	mm	mm	mm	mm	mm
7	Free lift height	mm	mm	mm	mm	mm	mm	mm	mm	mm	mm	mm	mm	mm	mm
8	Fork size	LxWxT	1070x120x40	1070x120x40	1070x120x40	1070x120x40	1070x120x40	1070x120x40	1070x120x40	1070x120x40	1070x120x40	1070x120x40	1070x120x40	1070x120x40	1070x120x40
9	Mast tilt range	deg	612	612	612	612	612	612	612	612	612	612	612	612	612
10	Fork overhang(wheel center to fork face)	mm	476	476	476	476	476	476	476	476	476	476	476	476	476
11	Rear overhang	mm	485	485	485	485	485	485	485	485	485	485	485	485	550
12	Length to face of fork	mm	2610	2610	2610	2610	2610	2610	2610	2610	2610	2610	2610	2660	2660
13	Overall width	mm	1150	1150	1150	1150	1150	1150	1150	1150	1150	1150	1150	1150	1150
14	Mast lowered height	mm	2050	2050	2050	2050	2050	2050	2050	2050	2050	2050	2050	2050	2050
15	Mast extended height	mm	4200	4200	4200	4200	4200	4200	4200	4200	4200	4200	4200	4200	4200
16	Overhead guard height	mm	2130	2130	2130	2130	2130	2130	2130	2130	2130	2130	2130	2130	2130
17	Turning radius(outside)	mm	2170	2170	2170	2170	2170	2170	2170	2170	2170	2170	2170	2170	2170
18	Min right angle stacking aisle width (Add load length and clearance)	mm	2680	2680	2680	2680	2680	2680	2680	2680	2680	2680	2680	2680	2680
19	Travel (No load)	Km/h	20	20	20	20	20	20	20	20	20	20	20	20	20
20	Speed	mm/sec	450	450	450	450	450	450	450	450	450	450	450	450	450
21	Lifting (Full load)	mm/sec	450	450	450	450	450	450	450	450	450	450	450	450	450
22	Max Drawbar Pull (Full load)	N	17500	17500	17500	17500	17500	17500	17500	17500	17500	17500	17500	17500	17500
23	Max Gradeability (Full load)	%	20	20	20	20	20	20	20	20	20	20	20	20	20
24	Types	mm	7.00-12-12PR	7.00-12-12PR	7.00-12-12PR	7.00-12-12PR	7.00-12-12PR	7.00-12-12PR	7.00-12-12PR	7.00-12-12PR	7.00-12-12PR	7.00-12-12PR	7.00-12-12PR	7.00-12-12PR	7.00-12-12PR
25	Rear	mm	6.00-9-10PR	6.00-9-10PR	6.00-9-10PR	6.00-9-10PR	6.00-9-10PR	6.00-9-10PR	6.00-9-10PR	6.00-9-10PR	6.00-9-10PR	6.00-9-10PR	6.00-9-10PR	6.00-9-10PR	6.00-9-10PR
26	Front	mm	970	970	970	970	970	970	970	970	970	970	970	970	970
27	Rear	mm	970	970	970	970	970	970	970	970	970	970	970	970	970
28	Wheelbase	mm	1600	1600	1600	1600	1600	1600	1600	1600	1600	1600	1600	1600	1600
29	Ground	mm	120	120	120	120	120	120	120	120	120	120	120	120	120
30	Clearance	mm	145	145	145	145	145	145	145	145	145	145	145	145	145
31	Self weight	Kg	3580	3580	3580	3580	3580	3580	3580	3580	3580	3580	3580	3580	3580
32	Weight	mm	4856	4856	4856	4856	4856	4856	4856	4856	4856	4856	4856	4856	4856
33	Front	mm	724	724	724	724	724	724	724	724	724	724	724	724	724
34	Rear	mm	1428	1428	1428	1428	1428	1428	1428	1428	1428	1428	1428	1428	1428
35	Weight Distribution	mm	2152	2142	2142	2142	2142	2142	2142	2142	2142	2142	2142	2142	2142
36	Battery	V/AH	12/60	12/60	12/60	12/60	12/60	12/60	12/60	12/60	12/60	12/60	12/60	12/60	12/60
37	Voltage/Capacity(20HR)	mm	SAS-DPEU2	CH40BP-G25	C240	TD27	GK25	CH40BP-G25	C240	TD27	GK25	CH40BP-G25	C240	TD27	GK25
38	Manufacture	mm	Mitsubishi	CHINA	ISUZU	GCT	CHINA	CHINA	ISUZU	GCT	Mitsubishi	ISUZU	CHINA	GCT	GCT
39	Rated output/p.m	kw	35.3/2250	36.8/2650	34.5/2500	38.5/2300	34.5/2500	36.8/2650	34.5/2500	38.5/2300	34.5/2500	36.8/2650	34.5/2500	38.5/2300	37.4/2300
40	Rated torque/p.m	N.m	1771/1700	156/1700-1900	139/1800	160/2300	156/1700-1900	1771/1700	1771/1700	156/1700-1900	139/1800	160/2300	1771/1700	160/2300	176.5/1600
41	No. of cylinder	4	4	4	4	4	4	4	4	4	4	4	4	4	4
42	Bore*Stroke	mm	94x102	90x105	86x102	96/92	86x102	90x105	86x102	96/92	86x102	90x105	86x102	96/92	89x100
43	Displacement	cc	3331	2670	2369	2663	2670	2369	2663	2670	2369	2663	2670	2663	2488
44	Fuel tank capacity	L	60	60	60	60	60	60	60	60	60	60	60	60	60
45	Manufacture	mm	CHINA	CHINA	CHINA	CHINA	CHINA	CHINA	CHINA	CHINA	CHINA	CHINA	CHINA	CHINA	CHINA
46	Transmissions	Type	Powershift	Powershift	Powershift	Powershift	Powershift	Powershift	Powershift	Powershift	Powershift	Powershift	Powershift	Powershift	Powershift
47	Stage	mm	1/1	2/2	1/1	1/1	1/1	2/2	1/1	1/1	1/1	1/1	1/1	1/1	1/1
48	Operating pressure	Mpa	17.5	17.5	17.5	17.5	17.5	17.5	17.5	17.5	17.5	17.5	17.5	17.5	17.5

1. Special lifting height available (2-stage mast : 2.5m, 2.7m, 3.0m, 3.3m, 3.5m, 3.6m, 3.7m, 4m, 4.3m, 4.5m, 5m. Full Free Duplex Mast 3.0m, 3.3m, 3.5m, 3.6m, 3-stage mast : 4.3m, 4.5m, 4.8m, 5m, 5.5m, 6m)
 2. Attachment available.
 3. The parameters in the table are of the standard model. For more information, please contact us. 4. Specification are subject to change without notice.

1.5-1.8t T8 series mast: (pneumatic)

Type	Model	Max.fork height	Overall height				Free lift		Front Overhang		Tilt range		Capacity			
			Lowered	Extended		Without backrest	With backrest	1.5t	1.8t	FWD	BWD	Load capacity at 500 mm				
				Without backrest	With backrest							Single tire		Double tire		
												1.5t	1.8t	1.5t	1.8t	
mm	mm	mm	mm	mm	mm	mm	mm	Deg	Deg	kg	kg	kg	kg			
Wide view mast	2W200	2000	1495	2585	2955	120	120	420	420	6	12	1500	1800	1500	1800	
	2W250	2500	1745	3085	3455	120	120	420	420	6	12	1500	1800	1500	1800	
	2W270	2700	1845	3285	3655	120	120	420	420	6	12	1500	1800	1500	1800	
	2W300	3000	1995	3585	3955	120	120	420	420	6	12	1500	1800	1500	1800	
	2W330	3300	2145	3885	4255	120	120	420	420	6	12	1500	1800	1500	1800	
	2W350	3500	2245	4085	4455	120	120	420	420	6	12	1500	1800	1500	1800	
	2W360	3600	2295	4185	4555	120	120	420	420	6	12	1500	1800	1500	1800	
	2W400	4000	2545	4585	4955	120	120	420	420	6	12	1400	1700	1500	1800	
	2W430	4300	2695	4885	5255	120	120	420	420	6	6	1300	1600	1400	1700	
	2W450	4500	2795	5085	5455	120	120	420	420	6	6	1250	1500	1350	1600	
wide view full 2-stage mast	2F250	2500	1790	3105	3455	1045	765	420	420	6	12	1500	1800	1500	1800	
	2F270	2700	1890	3305	3655	1145	865	420	420	6	12	1500	1800	1500	1800	
	2F300	3000	2040	3605	3955	1345	1105	420	420	6	12	1500	1800	1500	1800	
	2F330	3300	2190	3905	4255	1495	1165	420	420	6	12	1500	1800	1500	1800	
	2F360	3600	2340	4205	4555	1645	1315	420	420	6	12	1500	1800	1500	1800	
	2F400	4000	2540	4605	4955	1815	1565	420	420	6	12	1400	1700	1500	1800	
wide view full 3-stage mast	3F430	4300	1965	5070	5255	1425	1080	440	440	6	6	1250	1500	1350	1600	
	3F450	4500	2045	5130	5465	1485	1140	440	440	6	6	1200	1400	1300	1500	
	3F480	4800	2160	5445	5755	1575	1230	440	440	6	6	1100	1300	1200	1400	
	3F500	5000	2210	5605	5955	1665	1320	440	440	6	6	1050	1200	1150	1300	
	3F550	5500	2375	6120	6455	1825	1480	440	440	3	6	/	/	950	1100	
	3F600	6000	2600	6695	6955	1975	1630	440	440	3	6	/	/	750	900	

Note:1. With sideshifter minus 150Kg, with integral sideshifter minus 100Kg.

2.0-2.5t T8 series mast: (pneumatic)

Type	Model	Max.fork height	Overall height				Free lift		Front Overhang		Tilt range		Capacity			
			Lowered	Extended		Without backrest	With backrest	2.0t	2.5t	FWD	BWD	Load capacity at 500 mm				
				Without backrest	With backrest							Single tire		Double tire		
												2.0t	2.5t	2.0t	2.5t	
mm	mm	mm	mm	mm	mm	mm	mm	Deg	Deg	kg	kg	kg	kg			
Wide view mast	2W200	2000	1555	2740	3420	120	120	476	476	6	10	2000	2500	2000	2500	
	2W250	2500	1805	3040	3720	120	120	476	476	6	10	2000	2500	2000	2500	
	2W270	2700	1905	3240	3920	120	120	476	476	6	10	2000	2500	2000	2500	
	2W300	3000	2055	3540	4220	120	120	476	476	6	10	2000	2500	2000	2500	
	2W330	3300	2205	3690	4370	120	120	476	476	6	10	2000	2500	2000	2500	
	2W350	3500	2305	3890	4570	120	120	476	476	6	10	2000	2500	2000	2500	
	2W360	3600	2355	3990	4670	120	120	476	476	6	10	2000	2500	2000	2500	
	2W400	4000	2605	4040	4720	120	120	476	476	6	10	1900	2300	2000	2500	
	2W430	4300	2755	4340	5020	120	120	476	476	6	6	1800	2100	1950	2450	
	2W450	4500	2855	4290	4970	120	120	476	476	6	6	1700	2000	1900	2400	
wide view full 2-stage mast	2F250	2500	1785	2090	2770	1210	560	476	476	6	10	2000	2500	2000	2500	
	2F270	2700	1885	2290	2970	1310	660	476	476	6	10	2000	2500	2000	2500	
	2F300	3000	2035	2590	3270	1460	810	476	476	6	10	2000	2500	2000	2500	
	2F330	3300	2185	3840	4520	1610	960	476	476	6	10	2000	2500	2000	2500	
	2F360	3600	2335	4140	4820	1760	1110	476	476	6	10	2000	2500	2000	2500	
	2F400	4000	2585	4540	5220	2060	1410	476	476	6	10	1900	2300	2000	2500	
wide view full 3-stage mast	3F430	4300	2035	4880	5560	1360	730	490	490	6	6	1700	2000	1900	2400	
	3F450	4500	2115	5040	5720	1460	810	490	490	6	6	1600	1900	1800	2300	
	3F480	4800	2220	5345	6020	1565	915	490	490	6	6	1500	1700	1700	2100	
	3F500	5000	2305	5540	6220	1610	960	490	490	6	6	1400	1600	1600	2000	
	3F550	5500	2555	6120	6800	1770	1120	490	490	3	6	1050	1200	1500	1800	
	3F600	6000	2805	6540	7220	2020	1370	490	490	3	6	700	800	1400	1600	

Note:1. With sideshifter minus 150Kg, with integral sideshifter minus 100Kg.

3.0-3.5t T8 series mast: (pneumatic)

Type	Model	Max.fork height	Overall height				Free lift		Front Overhang		Tilt range		Capacity			
			Lowered	Extended		Without backrest	With backrest	3.0t	3.5t	FWD	BWD	Load capacity at 500 mm				
				Without backrest	With backrest							Single tire		Double tire		
												3.0t	3.5t	3.0t	3.5t	
mm	mm	mm	mm	mm	mm	mm	mm	Deg	Deg	kg	kg	kg	kg			
Wide view mast	2W200	2000	1570	2570	3250	120	120	481	486	6	10	3000	3000	3500	3500	
	2W250	2500	1820	3070	3750	120	120	481	486	6	10	3000	3000	3500	3500	
	2W270	2700	1920	3270	3950	120	120	481	486	6	10	3000	3000	3500	3500	
	2W300	3000	2070	3570	4250	120	120	481	486	6	10	3000	3000	3500	3500	
	2W330	3300	2220	3690	4370	120	120	481	486	6	10	3000	3000	3500	3500	
	2W350	3500	2320	3890	4570	120	120	481	486	6	10	3000	3000	3500	3500	
	2W360	3600	2370	3990	4670	120	120	481	486	6	10	3000	3000	3500	3500	
	2W400	4000	2620	4040	4720	120	120	481	486	6	10	2850	3000	3250	3500	
	2W430	4300	2770	4340	5020	120	120	481	486	6	6	2700	2900	3000	3400	
	2W450	4500	2870	4290	4970	120	120	481	486	6	6	2550	2850	2850	3350	
wide view full 2-stage mast	2F250	2500	1805	2220	2900	1210	560	481	486	6	10	3000	3000	3500	3500	
	2F270	2700	1905	2320	3000	1310	660	481	486	6	10	3000	3000	3500	3500	
	2F300	3000	2055	2620	3300	1460	810	481	486	6	10	3000	3000	3500	3500	
	2F330	3300	2205	3870	4550	1610	960	481	486	6	10	3000	3000	3500	3500	
	2F360	3600	2355	4020	4700	1760	1110	481	486	6	10	3000	3000	3500	3500	
	2F400	4000	2605	4420	5100	2060	1410	481	486	6	10	2850	3000	3250	3500	
wide view full 3-stage mast	3F430	4300	2055	4910	5570	1360	730	495	500	6	6	2550	2850	2850	3350	
	3F450	4500	2135	5070	5750	1460	810	495	500	6	6	2400	2700	2700	3200	
	3F480	4800	2240	5375	6050	1565	915	495	500	6	6	2250	2550	2450	2950	
	3F500	5000	2325	5570	6250	1610	960	495	500	6	6	1650	2250	2300	2800	
	3F550	5500	2575	6150	6830	1770	1120	495	500	3	6	1800	2250	1800	2550	
	3F600	6000	2825	6570	7250	2020	1370	495	500	3	6	1200	2100	1300	2300	

Note:1. With sideshifter minus 200Kg, with integral sideshifter minus 150Kg.

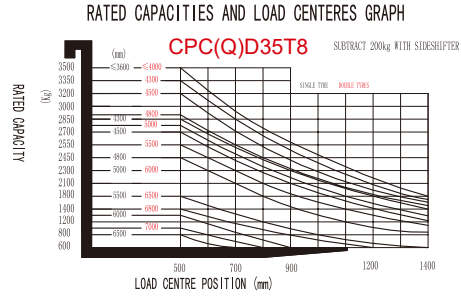
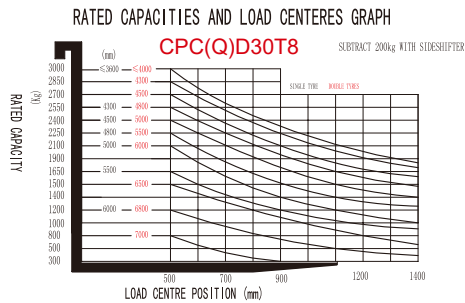
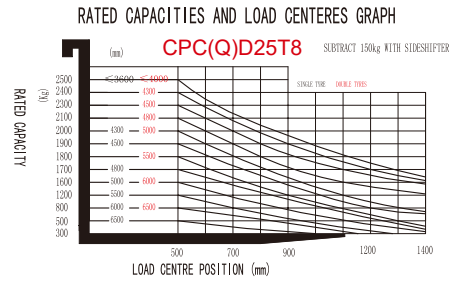
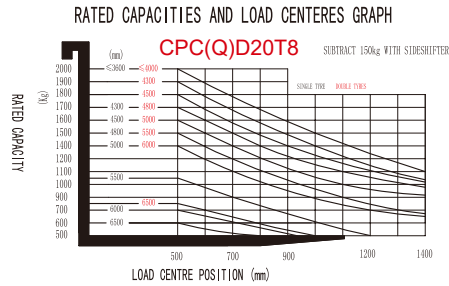
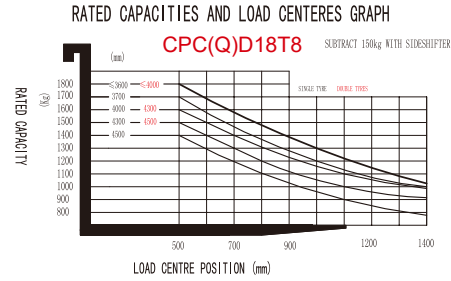
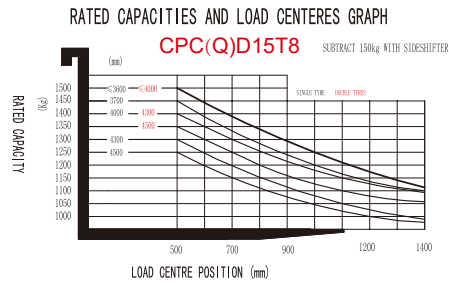

Option

Options	15/18T8	20/25T8	30T8	35T8
1 Fork length	○	○	○	○
2 Fork extension	○	○	○	○
3 Folded fork	○	○	○	○
4 Imported diesel engine	○	○	○	○
5 Import Gasoline Engine	○	○	○	○
6 LPG system	○	○	○	○
7 High exhaust	○	○	○	○
8 Dual air cleaners or special air cleaner	○	○	○	○
9 Solid rubber tire	○	○	○	○
10 No marking solid tire	○	○	○	○
11 Overhead guard	●	●	●	●
12 Mast options	○	○	○	○
13 Attachments	○	○	○	○
14 Integrated side shift	○	○	○	○
15 Cockpit	●	●	●	●
16 heater	○	○	○	○
17 Front windshield with wiper	○	○	○	○
18 Rear windshield with wiper	○	○	○	○
19 Fan	○	○	○	○
20 Full steel cabin room	○	○	○	○
21 LED front light	●	●	●	●
22 Rear working LED light	○	○	○	○
23 Fire extinguisher	○	○	○	○
24 Suspension seat	○	○	○	○
25 Seat switch	●	●	●	●
26 Warning light	●	●	●	●
27 Insulation mat	○	○	○	○
28 Double front tyre	○	○	○	○
29 OPS system	○	○	○	○

Note: ● standard ○ option — NA

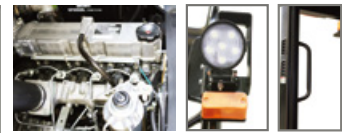
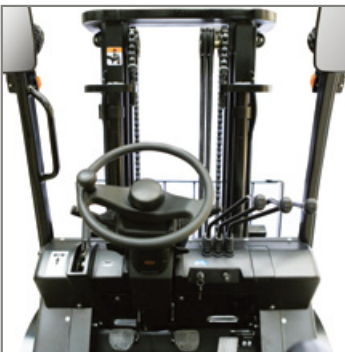
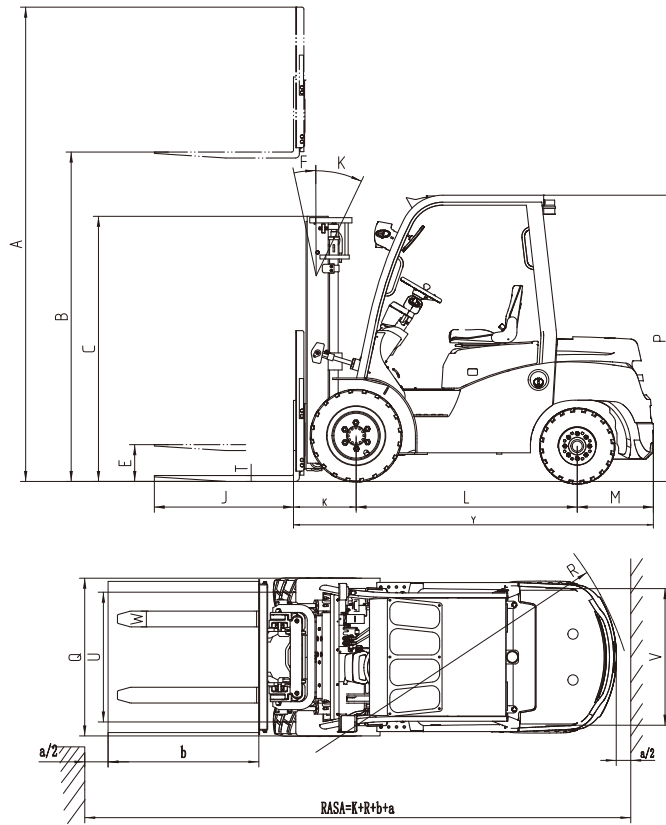

MAX-8



MAX-8

Excellent Performances & Reliability

CPCD45T8/CPCD50T8-X

T8 Diesel Forklift 4.5/5.0t

EP EQUIPMENT CO.,LTD
www.ep-ep.com



CPCD45T8/CPCD50T8-X

T8 Diesel Forklift 4.5/5.0t

		EP			
		CPCD45T8	CPCD50T8-X	CPCD45T8	CPCD50T8-X
		Diesel	Diesel	Diesel	Diesel
1	Manufacture				
2	Model				
3	Power type				
4	Rated capacity	Kg	5000	4500	5000
5	Load center	mm	500	500	500
6	Lift height	mm	3000	3000	3000
7	Free lift height	mm	150	150	150
8	Fork size	LxWxT	1070x150x55	1070x150x55	1070x150x55
9	Mast tilt range	F/R	6/10	6/10	6/10
10	Fork overhang(wheel center to fork face)	mm	565	565	565
11	Rear overhang	mm	540	540	540
12	Length to face of fork	mm	3070	3070	3070
13	Overall width	mm	1480	1480	1480
14	Mast lowered height	mm	2265	2265	2265
15	Mast extended height	mm	4250	4250	4250
16	Overhead guard height	mm	2280	2280	2280
17	Turning radius(outside)	mm	2830	2830	2830
18	Min.right angle stacking aisle width (Add load length and clearance)	mm	3595	3595	3595
19	Speed	Km/h	26/22	26/22	26/22
20	Lifting (No/Full load)	mm/sec	570/470	570/470	570/470
21	Max.Drawbar Full (full load)	N	21000	21000	21000
22	Max.Gradeability (Full load)	%	20	20	20
23	Tires	mm	300-15-14PR	300-15-14PR	300-15-14PR
24	Front	mm	700-12-12PR	700-12-12PR	700-12-12PR
25	Rear	mm	1180	1180	1180
26	Font	mm	1190	1190	1190
27	Rear	mm	2000	2000	2000
28	Wheelbase	mm	165/140	165/140	165/140
29	Mast	mm	195/180	195/180	195/180
30	Frame	mm	6770	6770	6770
31	Self weight	Kg	9805	9805	9805
32	Full load	kg	1465	1465	1465
33	Rear	kg	3046	3046	3046
34	No load	kg	3724	3724	3724
35	Distribution	V/AH	24/60	24/60	24/60
36	Battery	V/AH	12/80	12/80	12/80
37	Modal		S6S	QS2.8	4D35ZG31
38	Manufacture		MITSUBISHI	CUMMINS	XIN CHAI
39	Rated output/r.p.m	kw	52/2300	55/2200	60/2200
40	Rated torque/r.p.m	N.m	248/1700	300/1600	300/1600-1800
41	No.of cylinder		6	4	4
42	Borex.Stroke	mm	94*120	94*100	98*115
43	Displacement	cc	4996	2775	3460
44	Fuel tank capacity	L		90	
45	Manufacture		CHINA	CHINA	CHINA
46	Transmissions	Type		Powershift	
47	Stage	FWD/RVS		2/1	
48	Operating pressure	Mpa		17.5	

1. The parameters in the table are of the standard model. For more information, please contact us.
 2. The parameters are subject to change without notice.

Mast Option

4.5/5.0t T8 series mast: (pneumatic)

Type	Model	Max. fork height	Overall height			Free lift		Front Overhang	Tilt range		Capacity	
			Lowered	Extended		Without backrest	With backrest		FWD	BWD	Load capacity at 500 mm	
				Without backrest	With backrest						4.5t	5.0t
			mm	mm	mm	mm	mm		mm	Deg	Deg	kg
Wide view mast	2W300	3000	2280	4175	3770	145	145	565	6	10	4500	5000
	2W330	3300	2430	4475	4070	145	145	565	6	10	4500	5000
	2W350	3500	2530	4675	4270	145	145	565	6	10	4500	5000
	2W370	3700	2630	4875	4470	145	145	565	6	10	4350	4800
	2W400	4000	2830	5175	4770	145	145	565	6	6	4250	4750
	2W425	4250	2955	5425	5020	145	145	565	6	6	3800	4250
wide view full 2-stage mast	2W450	4500	3080	5675	5270	145	145	565	6	6	3150	3500
	2F271	2710	2250	3885	3480	1055	1355	565	6	10	4500	5000
	2F300	3000	2395	4175	3770	1200	1500	565	6	10	4500	5000
	2F330	3300	2545	4475	4070	1350	1650	565	6	10	4500	5000
wide view full 3-stage mast	2F350	3500	2645	4675	4270	1450	1750	565	6	10	4500	5000
	3F400	4000	2080	4780	5200	1230	900	578	6	6	4000	4500
	3F435	4350	2195	5130	5550	1345	1015	578	6	6	3800	4250
	3F450	4500	2245	5280	5700	1395	1065	578	6	6	3600	4000
	3F470	4700	2310	5480	5900	1460	1130	578	6	6	3350	3750
	3F500	5000	2460	5780	6200	1610	1280	578	6	6	3150	3500
	3F550	5500	2680	6280	6700	1830	1500	578	3	6	2550	2850
	3F600	6000	2845	6780	7200	1995	1665	578	3	6	1950	2200

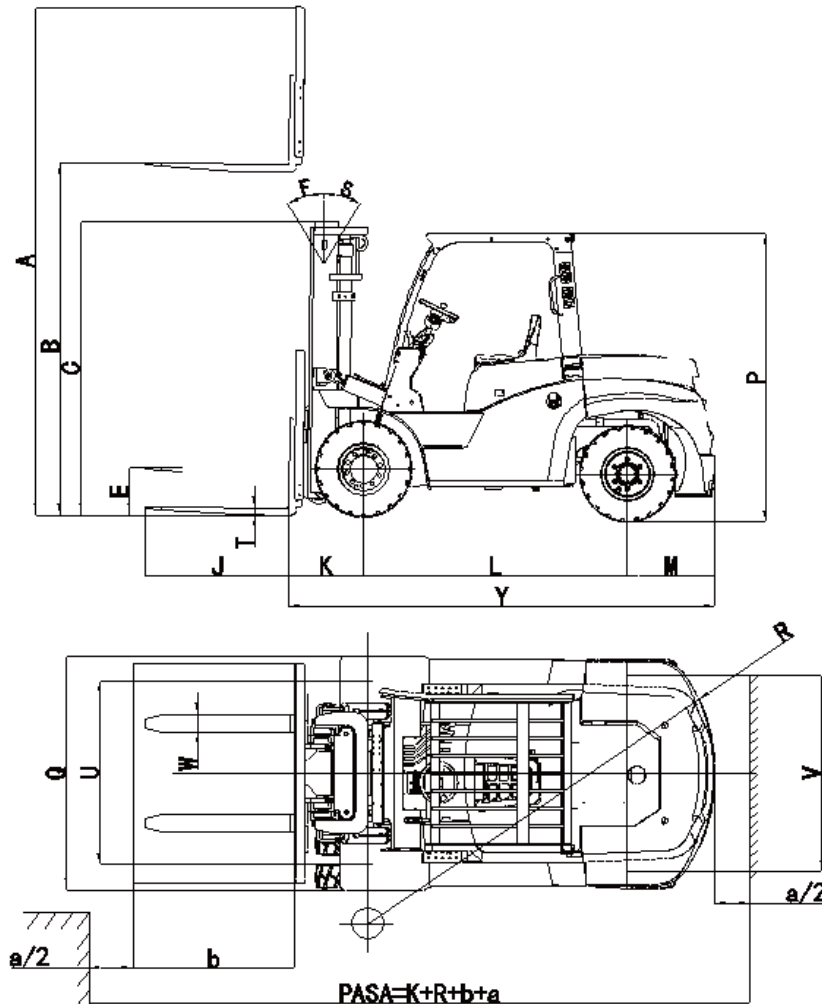

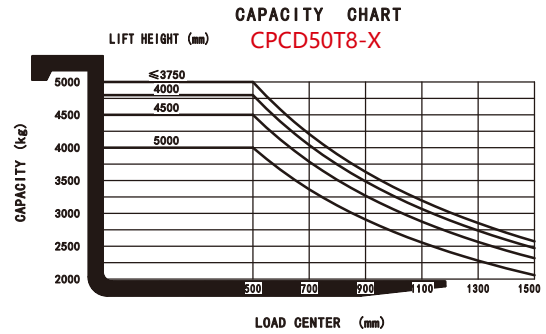
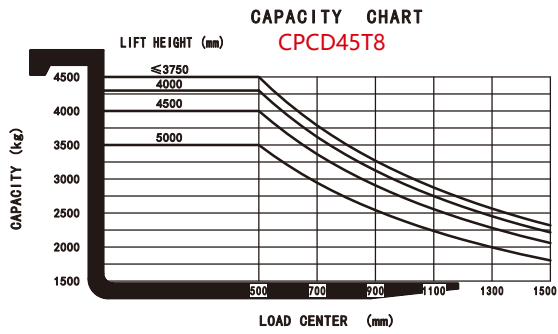

Option

Options		45T8	50T8-X
1	Fork length	○	○
2	Fork extension	○	○
3	Fold fork	○	○
4	Imported diesel engine	○	○
5	High exhaust	○	○
6	Dual air cleaners or special air cleaner	○	○
7	Solid rubber tire	○	○
8	No marking solid tire	○	○
9	Overhead guard	●	●
10	Mast options	○	○
11	Attachments	○	○
12	Integrated side shift	○	○
13	Cabin	○	○
14	Heater	○	○
15	Front windshield with wiper	○	○
16	Rear windshield with wiper	○	○
17	Fan	○	○
18	Cabin without side door	○	○
19	Fire extinguisher	○	○
20	Suspension seat	○	○
21	Front work light	●	●
22	Rear working LED light	○	○
23	OPS system	○	○

Note: ● standard ○ option — NA

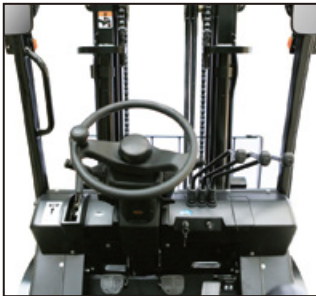

MAX-8



EP
Let's grow together

MAX-8

Excellent Performances & Reliability

CPCD50-100T8

T8 Diesel Forklift 5.0/6.0/7.0/8.0/10.0t

EP EQUIPMENT CO.,LTD
www.ep-eq.com



CPCD50/60/70T8

T8 series 5.0-7.0t forklift specification:

		EP												
		CPCD50T8	CPCD60T8	CPCD70T8	CPCD50T8	CPCD60T8	CPCD70T8	CPCD50T8	CPCD60T8	CPCD70T8	CPCD50T8	CPCD60T8	CPCD70T8	
General	1 Manufacture													
	2 Model	Diesel												
	3 Power type	Diesel												
	4 Rated capacity	Kg	5000	6000	7000	5000	6000	7000	5000	6000	7000	5000	6000	7000
	5 Load center	mm	600											
	6 Lift height	mm	3000											
Characteristics & Dimensions	7 Free lift height	mm	130											
	8 Fork size	L×W×T	1220×150×55 1220×150×60 1220×150×65 1220×150×65 1220×150×65 1220×150×65 1220×150×65 1220×150×65 1220×150×65 1220×150×65											
	9 Mast tilt range	F/R	6/12											
	10 Fork overhang(wheel center to fork face)	mm	635											
	11 Rear overhang	mm	700	770	810	700	770	810	700	770	810	700	770	810
	12 Length to face of fork	mm	3455	3592	3592	3472	3592	3592	3472	3592	3592	3472	3592	3592
	13 Overall width	mm	1995											
	14 Mast lowered height	mm	2510											
	15 Mast extended height	mm	4429											
	16 Overhead guard height	mm	2410											
Performance	17 Turning radius(outside)	mm	3330	3440	3480	3330	3440	3480	3330	3440	3480	3330	3440	3480
	18 Minimum rectangular aisle width.	mm	4068	4218	4218	4068	4218	4218	4068	4218	4218	4068	4218	4218
	19 Speed	Km/h	26											
	20 Lifting (Full load)	mm/sec	500/430	500/380	500/380	500/380	500/380	500/380	500/380	500/380	500/380	500/380	500/380	500/380
	21 Max. Drawbar Pull (Full load)	N	21000	22200	24400	21000	22200	24400	21000	22200	24400	21000	22200	24400
	22 Max. Gradeability (Full load)	%	20											
	23 Tyres	mm	8.25-15-14PR											
	24 Front	mm	8.25-15-14PR											
	25 Rear	mm	1470											
	26 Tread	mm	1700											
Chassis	27 Wheelbase	mm	2250											
	28 Ground clearance	mm	200/160											
	29 Mast (No/Full load)	mm	240/200											
	30 Frame (No/Full load)	mm	200/160											
	31 Self weight	Kg	8000	8650	9050	8000	8650	9050	8000	8650	9050	8000	8650	9050
	32 Full load	kg	10660	12452	13842	10660	12452	13842	10660	12452	13842	10660	12452	13842
	33 Weight distribution		2340	2198	2028	2340	2198	2028	2340	2198	2028	2340	2198	2028
	34 No load	kg	2800	3028	3168	2800	3028	3168	2800	3028	3168	2800	3028	3168
	35 Voltage/Capacity	V/AH	5200	5622	5882	5200	5622	5882	5200	5622	5882	5200	5622	5882
	Power & transmission	36 Model	S6S-T	GSF3-8										
37 Manufacture		Mitsubishi	Cummins											
38 Rated output/r.p.m		kw	63.9/2300	86/2200										
39 Rated torque/r.p.m		N.m	285/1700	470/1520										
40 No. of cylinder			6	4										
41 Bore×Stroke		mm	94*120	102×115										
42 Displacement		cc	4996	3757										
43 Fuel tank capacity		L	140	140										
44 Manufacture				China										
45 Type				PowerShift										
Operating pressure	46 Stage		2/2											
	47 FWD/RVS		19											
	48 Operating pressure	Mpa												

1. Special lifting height available (2-stage mast : 2.5m, 2.7m, 3.0m, 3.3m, 3.5m, 3.6m, 3.7m, 4m, 4.3m, 4.5m, 5m, Full Free Duplex Mast 3.0m, 3.3m, 3.5m, 3.6m, 3-stage mast : 4.3m, 4.5m, 4.8m, 5m, 5.5m, 6m)

3. The parameters in the table are of the standard model. For more information, please contact us. 4. Specification are subject to change without notice.

2. Attachment available.

CPCD80/100T8

T8 series 8.0-10.0t forklift specification:

General		EP			
1	Manufacture	CPCD80T8	CPCD100T8	CPCD80T8	CPCD100T8
2	Model				
3	Power type	Diesel			
4	Rated capacity	8000	10000	8000	10000
5	Load center	600			
6	Lift height	3000			
7	Free lift height	200			
8	Fork size	1500×160×75	1500×160×80	1500×160×75	1500×160×80
9	Mast tilt range	6/12			
10	Fork overhang(wheel center to fork face)	728			
11	Rear overhang	680	700	680	700
12	Length to face of fork	3950	4250	3950	4250
13	Overall width	2245			
14	Mast lowered height	2850			
15	Mast extended height	4420			
16	Overhead guard height	2560			
17	Turning radius(outside)	3700	4050	3700	4050
18	Minimum rectangular aisle width.	4580	4950	4580	4950
19	Speed	25			
20	Lifting (Full load)	480/350	390/340	480/350	390/340
21	Max.Drawbar Pull (Full load)	25600	28500	25600	28500
22	Max.Gradeability (Full load)	20			
23	Tyres	4900-20-14PR			
24	Tread	2×900-20-14PR			
25	Wheelbase	1600			
26	Ground clearance	1700			
27	Mast (No/Full load)	2500	2800	2500	2800
28	Frame (No/Full load)	240/190			
29	Self weight	350/340			
30	Full load	11050	12900	11050	12900
31	Rear	17200	20900	17200	20900
32	Front	1850	1960	1850	1960
33	No load	4900	6260	4900	6260
34	Voltage/Capacity	6150	6640	6150	6640
35	Modul	6RG332			
36	Manufacture	China			
37	Rated output/r.p.m	85/2200			
38	Rated torque/r.p.m	450/1400-1800			
39	No.of cylinder	6			
40	Bore×Stroke	102×118			
41	Displacement	5785			
42	Fuel tank capacity	160			
43	Type	China			
44	Stage	Powershift			
45	Operating pressure	2/2			
46		20.5			

1. Special lifting height available For further information please contact us. 2. Attachment available.

3. The specification in the table are for standard models only . For further information please contact us. 4. Specification are subject to change without notice.

5.0/6.0/7.0t T8 series mast: (pneumatic)

Type	Model	Max.fork height	Overall height				Free lift		Front Overhang	Tilt range		Capacity				
			Lowered	Extended		Without backrest	With backrest	FWD		BWD	Load capacity at 600 mm					
				Without backrest	With backrest						5.0t	6.0t	7.0t			
				mm	mm									mm	mm	mm
Wide view mast	2W300	3000	2510	4000	4430	130	130	635	6	12	5000	6000	7000			
	2W330	3300	2660	4200	4730	130	130	635	6	12						
	2W350	3500	2760	4500	4930	130	130	635	6	12						
	2W400	4000	3020	5000	5430	130	130	635	6	12						
	2W450	4500	3310	5500	5930	130	130	635	6	6						
	2W550	5500	3860	6500	6930	130	130	635	6	6				4800	5800	6800
Wide view full 2-stage mast	2F300	3000	2460	4000	4430	1545	1090	635	6	12	5000	6000	—			
	2F330	3300	2610	4300	4730	1695	1240	635	6	12						
	2F350	3500	2710	4500	4930	1795	1340	635	6	12						
	2F400	4000	3010	5000	5430	2095	1640	635	6	12						
Wide view full 3-stage mast	3F450	4500	2650	5750	5070	1740	1285	680	6	6	4500	5500	6500			
	3F480	4800	2765	6050	5375	1845	1390	680	6	6						
	3F500	5000	2830	6250	5575	1910	1455	680	3	6						
	3F540	5400	2965	6830	6150	2045	1590	680	3	6				4200	5200	5500
	3F600	6000	3165	7250	6570	2245	1790	680	3	6				4000	5000	5300

8.0/10.0t T8 series mast: (pneumatic)

Type	Model	Max.fork height	Overall height			Free lift		Front Overhang		Tilt range		Capacity	
			Lowered	Extended		Without backrest	With backrest	8.0t	10.0t	FWD	BWD	Load capacity at 600 mm	
				Without backrest	With backrest							8.0t	10.0t
				mm	mm								
Wide view mast	2W300	3130	2920	4310	210	210	728	728	6	12	8000	10000	
	2W330	3430	3070	4610	210	210	728	728	6	12			
	2W350	3630	3170	4810	210	210	728	728	6	12			
	2W400	4130	3470	5310	210	210	728	728	6	12			
	2W450	4630	3720	5810	210	210	728	728	6	12			
	2W550	5130	3970	6310	210	210	728	728	6	6			7200
Wide view full 3-stage mast	3F450	4530	2900	5875	1580	1580	768	768	6	6	7200	7800	
	3F480	4830	3000	6175	1680	1680	768	768	6	6	7000	7650	
	3F500	5030	3065	6375	1745	1745	768	768	6	6	6300	7500	
	3F550	5530	3255	6775	1935	1935	768	768	3	6	6500	7200	
	3F600	6030	3455	7375	2135	2135	768	768	3	6	6000	6000	

RATED CAPACITIES AND LOAD CENTERS GRAPH

CPCD50T8

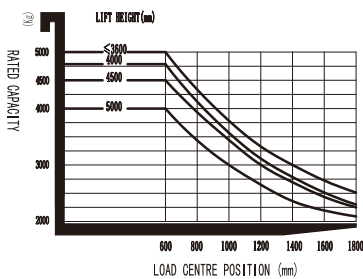

RATED CAPACITIES AND LOAD CENTERS GRAPH

CPCD70T8

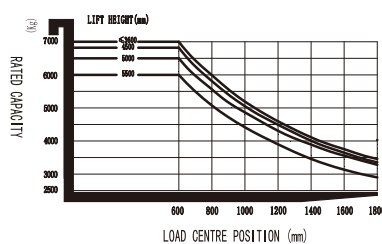

RATED CAPACITIES AND LOAD CENTERS GRAPH

CPCD100T8

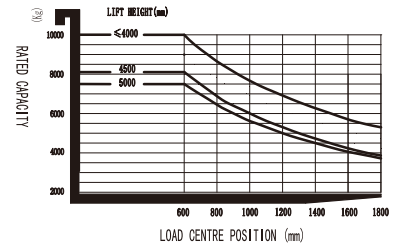

RATED CAPACITIES AND LOAD CENTERS GRAPH

CPCD60T8

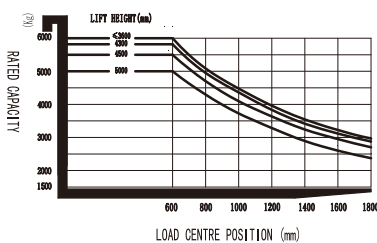

RATED CAPACITIES AND LOAD CENTERS GRAPH

CPCD80T8

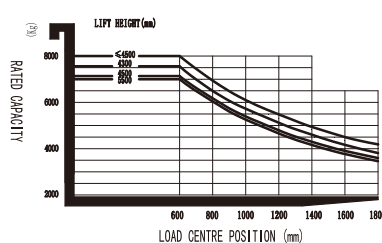

T8 series 5.0-7.0t forklift

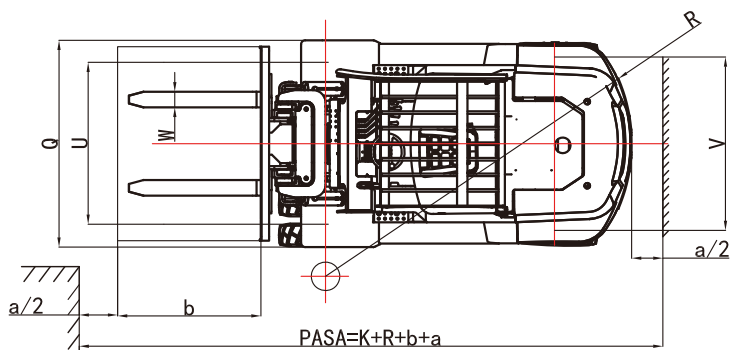
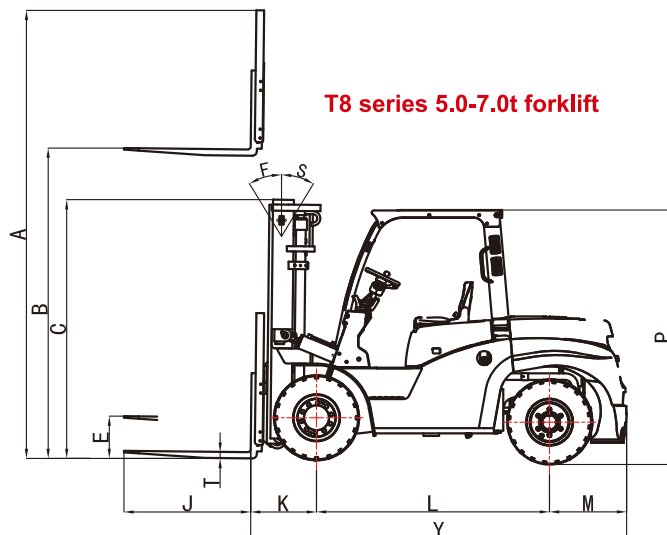

T8 series 8.0-10.0t forklift

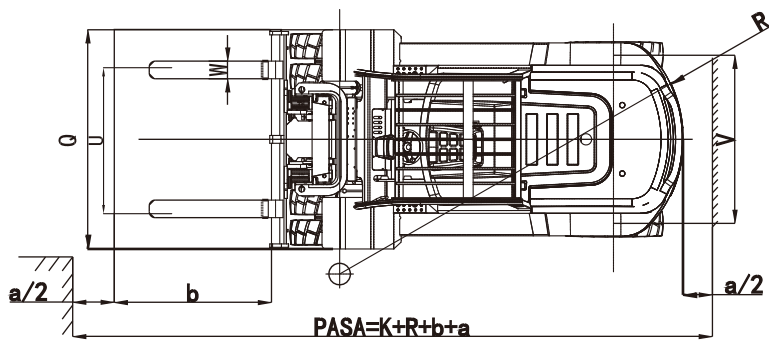
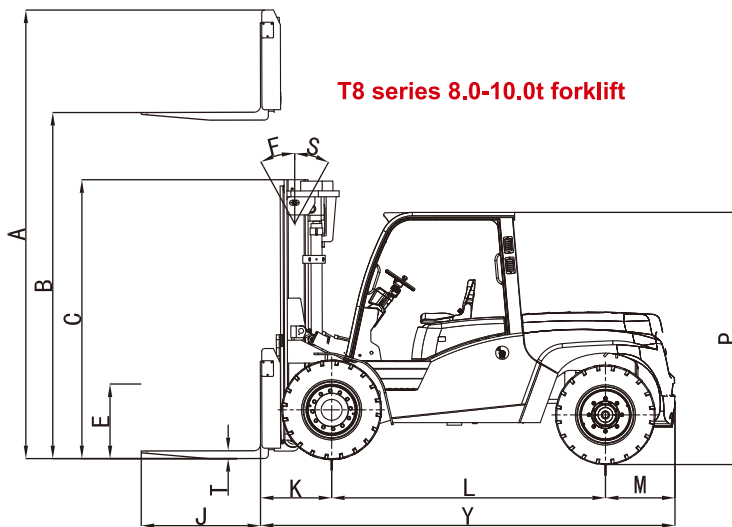

Option

Options	CPCD50T8	CPCD60T8	CPCD70T8	CPCD80T8	CPCD100T8
1 Other dimension forks	o	o	o	o	o
2 Fork Extension	o	o	o	o	o
3 Folding fork	o	o	o	o	o
4 Fork positioner	o	o	o	o	o
5 Imported engine	o	o	o	o	o
6 High-mounted Exhaust system	o	o	o	o	o
7 Dual air cleaner	o	o	o	o	o
8 Solid tyre	o	o	o	o	o
9 No-mark tyre	o	o	o	o	o
10 Special height overhead guard	o	o	o	o	o
11 Overhead guard rainproof hood	●	●	●	●	●
12 Different lifting height masts	o	o	o	o	o
13 Attachment	o	o	o	o	o
14 Cabin	o	o	o	o	o
15 Heater	o	o	o	o	o
16 Front window with wiper	o	o	o	o	o
17 Rear window with wiper	o	o	o	o	o
18 Cabin without side doors	●	●	●	●	●
19 LED Front working light	●	●	●	●	●
20 LED rear working light	o	o	o	o	o
21 Fire extinguisher	o	o	o	o	o
22 Luxury Seat(full suspension)	o	o	o	o	o
23 Seat switch	●	●	●	●	●
24 Warning light under engine cover	o	o	o	o	o
25 Insulation mat	o	o	o	o	o
26 OPS system	o	o	o	o	o
27 Special carriage and backrest	o	o	o	o	o
28 FAN	o	o	o	o	o

Note: ● standard o option — NA

T8 series 5.0-7.0t forklift



T8 series 8.0-10.0t forklift





ISO 9001



CE CERTIFICATE



Electric forklift pioneer of China
One stop warehouse equipment manufacturer
Global intralogistics service provider

EP EQUIPMENT CO., LTD

NO.121YongHua Street,Shi Qiao Road,
Xia Cheng Qu, Hangzhou, China
Tel:86-571-28035656/28878695
Fax:86-571-28035665
E-mail:info@ep-ep.com
www.ep-ep.com

Let's grow together